

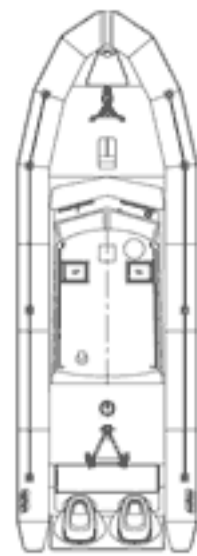

TECHNICAL SPECS.

[S-SERIES]



	S-6.5	S-8.0	S-9.5 CABIN
<b>Overall Length</b> Excluding the Engines	6430mm	7800mm	9800mm
<b>Beam Max</b> Inflated	2490mm	2500mm	3150mm
<b>Length Rigid Hull</b> From Transom to Bow	6520mm	6930mm	8350mm
<b>Beam Rigid Hull</b>	1950mm	2010mm	2460mm
<b>Depth</b> Top of the Tube to Deck	535mm	555mm	665mm
<b>Tube Diameter</b>	480mm	480mm	550mm
<b>No. of Air Compartments</b>	5	5	7
<b>Tube Volume</b>	2.35 m3	2.8 m3	4.82 m3
<b>Transom Height-Single</b>	25"	30"	30"
<b>Transom Height-Double</b>	20"	25"	25"
<b>Person Capacity</b>	9	12	16
<b>Hull Material</b>	Reinforced Fiberglass	Reinforced Fiberglass	Reinforced Fiberglass
<b>Sponson Material</b>	Hypalon, 1670 DTFX	Hypalon, 1670 DTFX	Hypalon, 1670 DTFX
<b>Max. Horsepower</b>	250	500	600
<b>Min. Horsepower to Plane</b>	125	250	270
<b>Max. Speed</b> at Full Displacement	39 Kn	45 Kn	44 Kn
<b>Max. Speed</b> at Light Displacement	51 Kn	62 Kn	56 Kn
<b>Cruising Speed</b> at Full Displacement	27 Kn	29 Kn	31 Kn
<b>Fuel Capacity - Main</b>	150 L	450 L	500 L
<b>Fuel Capacity - Auxiliary</b>	Available Upon Request	Available Upon Request	400 L
<b>Weight</b> Boat Only	600 Kg	650 Kg	1450 Kg
<b>Weight</b> Light Condition	1155 Kg	1744 Kg	2637 Kg
<b>Weight</b> Full Displacement	1986 Kg	2818 Kg	4234 Kg
<b>Max. Load</b> Crew, Fuel & Carryon Load	765 Kg	935 Kg	1500 Kg
<b>Hoisting Weight</b> Light Condition Excl. Fuel	1155 Kg	2194 Kg	3137 Kg
<b>Fuel Consumption</b> Full Disp. & Cruising Speed	66 Lph	132 LpH	159 LpH

ASIS S-SERIES 6.5 BOAT PLANS



ASIS S-SERIES 6.5 TECHNICAL DRAWING

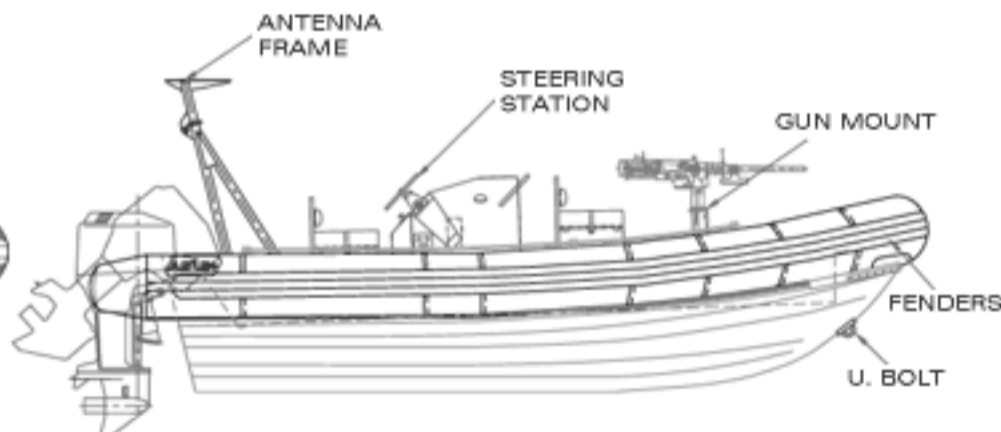
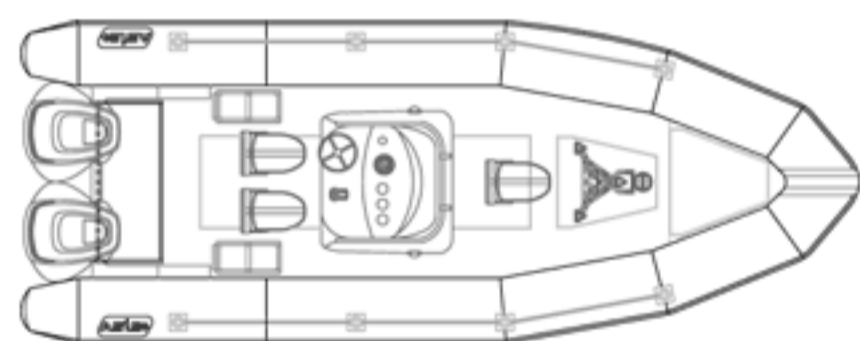

ASIS S-SERIES 8.0 BOAT PLANS

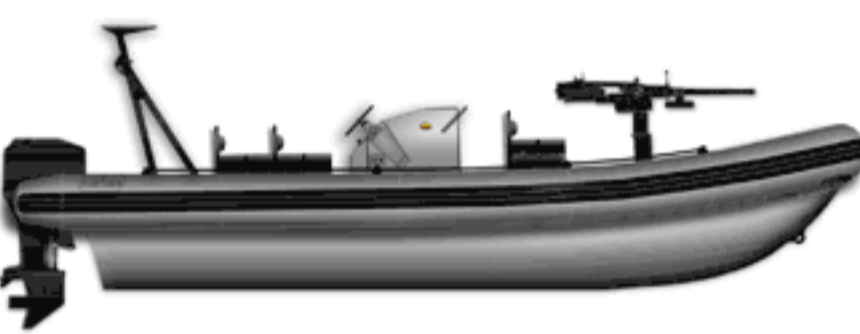

ASIS S-SERIES 8.0 TECHNICAL DRAWING

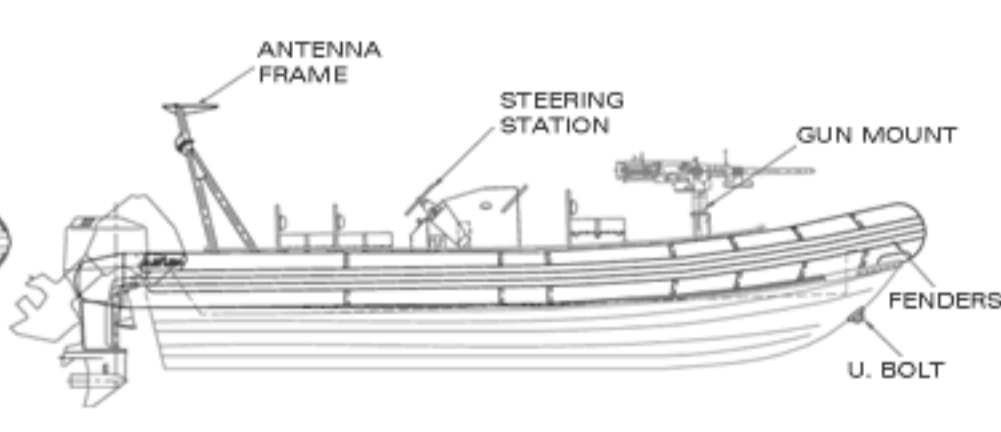
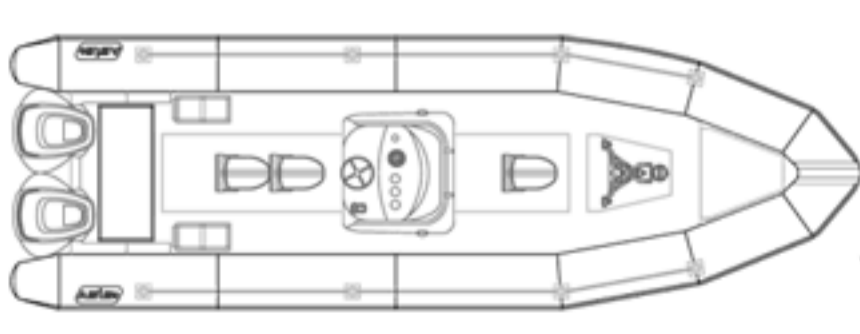

ASIS S-SERIES 9.5 CABIN BOAT PLANS



ASIS S-SERIES 9.5 CABIN TECHNICAL DRAWING

